



19inch wide touch screen panel
pc(1440*900),16:10, capacitive touch, A64
Quad-core Cortex-A53 2G+8G Capacitive
touch screen wifi IP65 for the front bezel

Category:	Industrial Panel PC Computers
Manufacturer:	Mobilator
Supported OS:	Android
Installed OS:	Android 6.0
Screen size:	19"
Resolution:	1440x900
Aspect ratio:	-----
Brightness:	300 cd/m2
Touchscreen:	capacitive
CPU Support:	Quad-core Cortex - A53
Installed CPU:	Quad-core Cortex - A53
Graphic Card:	Intel HD Graphics
Storage (HDD) Support:	SSD
Installed Storage (HDD):	8 GB SSD
Memory Support:	DDR3L SO-DIMM (max. 8GB)
Installed Memory:	2GB
IP Norm:	-----

IP Level (front panel):	IP65
IP Level (back panel):	-----
Temp:	-10°C ~ 50°C
Storage Temp:	-20°C ~ 60°C
Humidity:	0%~ 95%
Anti-shock:	-----
Anti-vibration:	-----
Barcode reader:	-----
RFID scanner (reader):	-----
Others:	Color Black
LAN:	Realtek RTL8111E 10/100/1000 Mb/s
Wireless LAN card:	802.11 a/b/g/n
3G:	No
Bluetooth:	No
GPS:	-----
Ports - rear panel:	DC-IN4x USB 2.01x RS2321x Gigabit LAN1x VGA1x HDMI
Ports - front panel:	-----
Ports - left panel:	-----
Ports - right panel:	-----
Expansion:	-----
Power:	12V DC-in
Power Consumption:	-----
Watch Dog Timer:	-----
Mounting VESA:	Yes
Folding Bracket (for office type working):	-----
Chipset:	Cortex
CD/DVD Drive:	-----
Audio:	-----

TV Tuner:	-----
Backlight MTBF:	LED
Contrast Ratio:	1000:1
Dual display:	Yes
Viewing Angle:	Full
Touch Life(contacts):	-----
Surface hardness (display):	-----
Color Resolution:	-----
Housing material:	Aluminium
Dimensions:	486 x 332 x 60mm
Fanless:	Yes
Weight:	1.4 kg

673,54 €

net price: 547,59 €

MobiTouch 19 LTA



SPECIFICATION AND PARAMETERS

DISPLAY AND TOUCH

RESISTANCE AND PROTECTION

COMMUNICATION AND CONNECTORS

APPLICATION

AVAILABLE VERSIONS AND ACCESSORIES

Industrial PC panels are integrated devices consisting of a PC computer and a touch monitor. Due to their design, they can work even under severe conditions prevailing in industrial environments, such as high humidity, high dustiness, contact with water or very low or high temperatures. These panels are characterized by high efficiency and stability of operation in all conditions.



Passive cooling

Use of passive cooling in the PC panel ensures silent operating and slows down deposition of dust.



Quick start

A modern SSD drive will increase the speed of applications and programs and ensure quiet computer operation.



Efficient

The quad-core Cortex processor supported by 2 GB of RAM improves the device's performance.



Bright Screen

The display with 300 cd/ m² brightness makes the picture much more vivid and better readable when used outside in the sun.



Wireless network

The panel can be connected to nearby wireless networks by equipping it with an optional Wi-Fi module.



Capacitive screen

The capacitive screen allows precise handling and gentle on-screen movement.

Specifications and parameters

Performance	
Processor	Quad-core Cortex - A53
Graphics card	Intel HD Graphics
Operating system	Android 6.0
RAM	2GB DDR3L
Drive	SSD: 8 GB
Display	
Screen	19" (1440x900)
Touch screen	capacitive
Brightness	350cd/m ²
Screen ratio	16:10
View angle	Full
Touch screen lifetime	>50.000.000
Interfaces	
Communication	802.11a/b/g/n
Connectors	4x USB 2.0 1x COM 1x LAN 1x VGA 1x HDMI DC 12V
Other	
Dimensions	486 x 332 x 60mm
Weight	1.4 kg
Casing material	Aluminum alloy

* Optional equipment, available only in specific versions of the device.



Detailed device specification is available in the "Technical data" tab.

The dust-proof industrial PC panel uses an efficient and energy-saving Quad-core Cortex - A53 processor. In its interior there are two cooperating cores enabling more efficient processing of many tasks at the same time. Shared cache memory in which a multi-level hierarchy is used is dynamically allocated to each processor core depending on the load. This reduces the average access time to the main memory. Improved graphics card technology allows you to enjoy movies at full resolution and HD quality.





More photos in full resolution available in the "Gallery" tab.

Display and touch

Amplified, waterproof industrial computer MobiTouch 19LTA has a water-resistant and scratch-proof 19" LED screen 1440x900 resolution offers good image quality, and high brightness in the 350 cd/m² range gives better color saturation and contrast and allows significantly improved visibility even in the case of incident. The display of the resistive type provides the user with a clear image and ease of use by touch.

CAPACITIVE SCREEN (AVAILABLE IN LTA VERSION)

The capacitive screen consists of a glass coating that is covered with an insulator. Touching the surface of the touch pad with your finger causes a disturbance in the flow of electric current. This display provides very good visibility under industrial conditions. The panel can be operated with one finger or conductive material (special glove). This type of screen provides support for multi-touch technology, which is a clear convenience during work. This is due to the fact that a large number of electrodes allows accurate detection of many points of touch. You do not have to use a stronger pressure for capacitive screens, because you only need to lightly brush the screen with your finger to make the device react.



Resistance and protection

QUALITY OF MATERIALS

Panel PC has a high quality casing made from aluminum alloys. It is a very crucial component of cooling system thanks to openings allowing air flow inside casing, specially important in a passive system. Overall design concentrates on simplicity and functionality which are in high demand amongst professionals.



EXTREME TEMPERATURES

PanelPC MobiTouch 19LTA is adapted for continuous operation in both very low and high temperatures in the range from -10 ° C to 50 ° C. If the device is switched off, it can already handle temperatures between -20 ° C and 60 ° C. In addition, the durable PanelPC is perfect for rooms with increased humidity, ensuring proper functioning even in the case of 95% relative humidity.

Work temp.	-10°C do 50°C
Storage temp.	-20°C do 60°C
Humidity	0% - 95%

Communication and connectors

WIRELESS WI-FI NETWORK

The dual-band Wi-Fi module provides quick access to the network wherever you can connect to secured or open Wi-Fi networks. This is a convenient solution for people who have a router at home or place of residence and a wireless network that can be used at no extra charge. The shockproof industrial panel MobiTouch 19LTA has been equipped with standards - 802.11n, which allows transfer of files at a dizzying speed of up to 150 Mb/s.

Standards	802.11a/b/g/n
Frequencies	2.4GHz 5GHz

CONNECTORS AND INTERFACES



DIMENSIONS

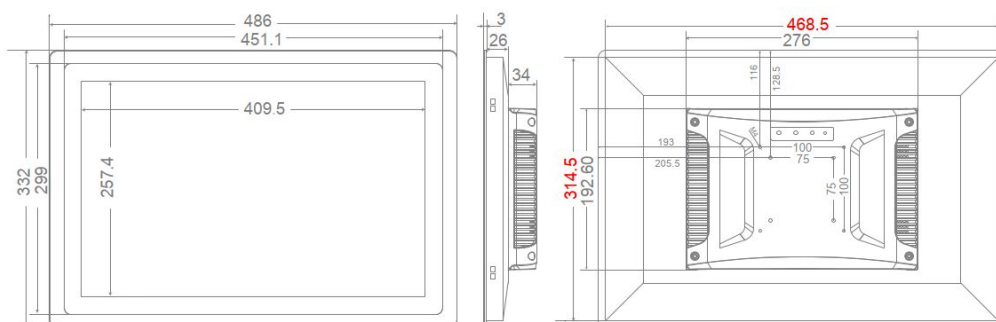

Application



TRADE AND SERVICES

PC Panel is widely used primarily in the commercial industry, for example for controlling the sales system, displaying product information on monitors or advertising on large screens. With the VESA holder in the housing there are many possibilities for its assembly, eg in stores (at the cash register) in factory halls, in a car delivering products, etc. It will certainly be used in all types of retail chains.

WAREHOUSE AND MANAGEMENT

The industrial panel computer thanks to the RS232 interface can be used to connect many devices in the warehouse and facilitate their control. And its rugged housing is ideally suited to the harsh conditions prevailing in such rooms. No dust or dirt will prevent him from working, he will work without complaints even in a large dusty and dirty environment.

TRANSPORT AND **M**OTORIZATION

Panel computers can be used in transport by adapting it to work on 12V power supply. Then Panel PC can be used in passenger cars, buses, trams, taxis, trains and even in airplanes. Thanks to the integrated monitor, these panels perform very well in vehicles where mobility and the small size of the device are important.

Available versions and accessories

Industrial Panel PC MobiTouch 19LTA is offered in several versions adapted to different needs. By clicking on the number of the hardware configuration you will be redirected to the product with the parameters given in the table below. In addition, it is possible to create a configuration that is currently unavailable on the customer's request.