



Industrial PanelPC MobiBOX 19 v.2

Category:	Industrial Panel PC Computers
Manufacturer:	Mobikator
Supported OS:	Microsoft Windows: XP/Vista/7/8/8.1; Linux
Installed OS:	-----
Screen size:	19"
Resolution:	1280 x 1024
Aspect ratio:	4:3
Brightness:	500 cd/m2
Touchscreen:	Resistive Type 5-Wire
CPU Support:	Inte Celeronl Dual Core 1037 (2 x 1.8GHz) / Intel® Atom™ Procesor D2550 (1M Cache, 2 x 1.86 GHz)
Installed CPU:	Inte Celeronl Dual Core 1037 (2 x 1.8GHz)
Graphic Card:	Intel HD Graphics
Storage (HDD) Support:	32 - 512 GB SSD / 320 - 1TB HDD
Installed Storage (HDD):	500 GB HDD
Memory Support:	up to 4GB (max);
Installed Memory:	2 GB
IP Norm:	-----

IP Level (front panel):	-----
IP Level (back panel):	-----
Temp:	-10°C ~ 60°C
Storage Temp:	-10°C ~ 60°C
Humidity:	0%~ 80%
Anti-shock:	-----
Anti-vibration:	-----
RFID scanner (reader):	-----
Others:	Housing color: Black / White
LAN:	Realtek RTL 8111E, 10/100/1000Mbit 1 x RJ45 Port
Wireless LAN card:	Yes
3G:	-----
Bluetooth:	-----
GPS:	-----
Ports - rear panel:	1x COM(RS-232) / 4x USB 2.0 / 1x HDMI / 1x VGA / 1xLAN / 1x Audio / 1x MIC / 1x DC-in
Ports - front panel:	-----
Ports - left panel:	-----
Ports - right panel:	-----
Expansion:	-----
Power:	12V DC-in
Power Consumption:	40 W
Watch Dog Timer:	-----
Mounting VESA:	Yes
Folding Bracket (for office type working):	Yes
Chipset:	Intel NM70
CD/DVD Drive:	-----
Audio:	Realtek ALG662 6 sound track audio frequency
TV Tuner:	-----

Backlight MTBF:	LED
Contrast Ratio:	1000:1
Dual display:	Yes
Viewing Angle:	H170/170 V160/160
Touch Life(contacts):	more than 35 000 000 times
Surface hardness (display):	-----
Color Resolution:	16.7 M
Response time touch-panel (ms):	5
Housing material:	Metal
Dimensions:	427 x 350 x 55 mm
Fanless:	No
Weight:	13 kg

Product from the Archive - production finished

MTouch Industrial PanelPC MobiBOX 19

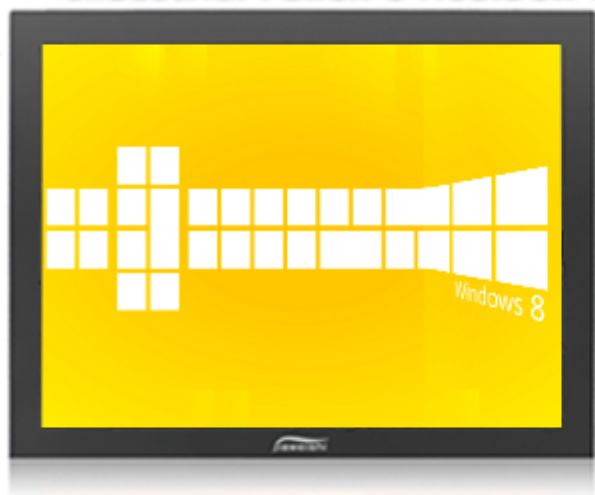

19" 19 inch



Resolution: 1280 * 1024



LED backlight



Screen Ratio: 4:3



Combine Multi Ports



Touch Accuracy: <0.2m

Industrial Panel PC

Industrial Panel PC are excelent in environments dominated by dust, dirt and moisture. They are ideal for applications that require quiet operation.

[go top...](#)



MTouch

Industrial PanelPC MobiBOX 19 v.1



CPU: Intel® Celeron™ Processor 1037U (2M Cache, 2 x 1.80 GHz) / Intel® Atom™ D2550 (1M Cache, 2 x 1.86 GHz) **(option)**



Memory: 2GB RAM



Disk: 500GB HDD / 64 SSD **(option)**



System: Windows 8.1/8 / Windows 7 / Windows XP / Linux



Screen: 19" / 1280x1024 / 4:3 / 5 - Wire Resistive



Expansion

cards: 2 x
Mini PCI
Express

Detailed
specification of
the configuration
available in the
"Technical
data"

Using the latest technology Panel PC is designed for continuous multitasking operating with low power consumption (**40 W**). An important advantage is the effective combination of small size with considerable opportunities, through the use of **Intel® Celeron** processor family, Intel chipsets and **DDR2** memory. Integrated Intel®HD Graphics video graphics card and audio Realtek ALC662 allow you to play a wide range of applications and media files (video, audio). Disks offer free space from **32GB** SSD to 512GB SSD (**320GB** to 1TB HDD option).

Dimensions:

Housing dimension are **427 (W) x 350 (L) x 55 (H) mm**. Housing is made of high quality aluminum what ensures a very high resistance to mechanical damages. This model with weight of only **13 kg** is ready at any time for operation even in extreme conditions such as heat, cold, vibration.

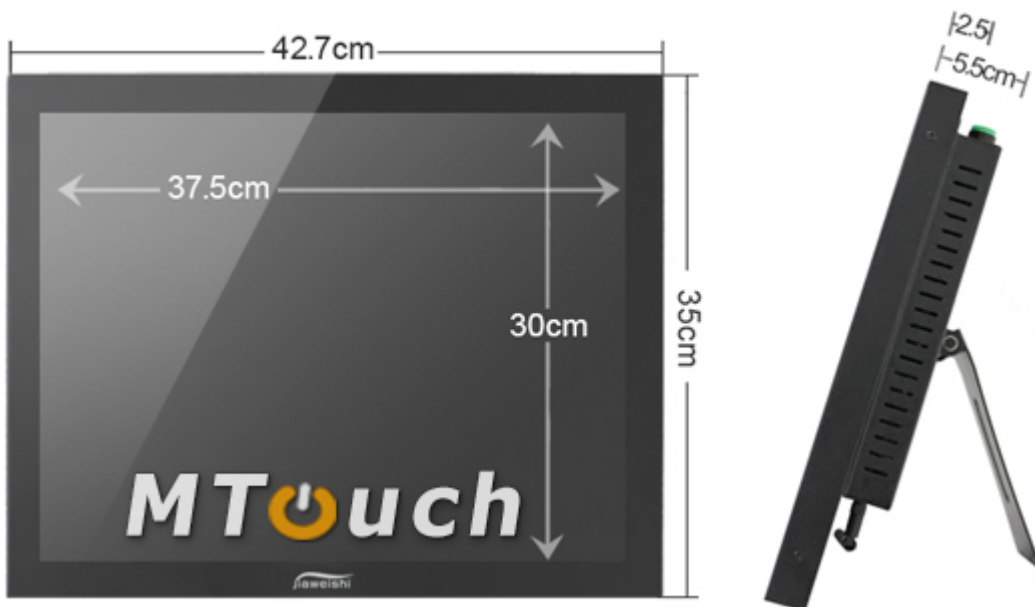

Cooling:

Industrial PanelPC MobiBOX 19 is a series of devices for industrial applications requiring continuous operation - 24 hours, 7 days a week.

MTouch



Communication:

Industrial PanelPC MobiBOX 19 standard has a system of wireless Wi-Fi communication. Optionally in other models are available also modules such as 3G.



Connector:

Integrated IntelRTL8111E LAN 1xRJ 1000M-45, WiFi module allows you to connect the device to the network. The computer is equipped with: one LAN connector, one COM ports (RS232), one VGA, one HDMI output, four USB 2.0 ports, one audio out, one microphone input, and a power DC-in.

MTouch



mobikator.pl

- 1. Antena WI-FI
- 2. COM (RS-232)
- 3. 2 x USB 2.0
- 4. HDMI

- 5. VGA
- 6. 2 x USB 2.0
- 7. LAN (RJ 45)
- 8. Audio

- 9. Mic
- 10. DC-in

Dual Display



Industrial PanelPC MobiBOX 19 has a water-resistant front panel and scratch resistant LED screen. With 1024x768 resolution and high brightness of 500 cd/m2, screen of "5 wire resistive" type with high sensitivity to touch, offers the user a clear picture and ease of use.



Resistive screen

A resistive touchscreen comprises of several layers, out of which the flexible plastic and glass layers are two important electrically resistive layers. The front surface of resistive touchscreen panel is a scratch-resistant plastic with coating of a conductive material (mostly Indium Tin Oxide, ITO), printed underside. The second important layer is either made of glass or hard plastic and is also coated with ITO. Both the layers face each other and are separated with a thin gap in between. An electrical resistance is created between both the layers in such a way that charge runs from top to bottom in one layer and side-to-side in another. When a finger or stylus tip presses down on the outer surface, both the ITO films meet. It is the measure of the resistance of both the layers at point of contact, which leads to get an accurate measurement of the touch position. The accuracy also relies on the evenness of the coating of ITO on both the layers.



