



MobiPad nBOX MK12F-V2 v.2 - Desktop mini computer for production management with 8GB RAM and 128GB SSD M.2, 2x RJ45 2.5 Gigabit LAN



<b>Category:</b>	MiniPC Industry
<b>Manufacturer:</b>	Mobikator
<b>Supported OS:</b>	Windows 11, Windows 10, Linux
<b>Installed OS:</b>	Windows 11 PRO (optional)
<b>Chipset:</b>	Intel Alder Lake-U
<b>CPU Support:</b>	12th and 13th generation Intel Core
<b>Installed CPU:</b>	Intel Core i3-1215U
<b>Graphic Card:</b>	Intel UHD Graphics
<b>Memory Support:</b>	DDR4
<b>Installed Memory:</b>	<b>8GB RAM</b>
<b>Storage (HDD) Support:</b>	SSD M.2 - NVMe
<b>Installed Storage (HDD):</b>	<b>128GB SSD M.2 - NVME</b> 256GB   512GB (optional)
<b>IP Norm:</b>	None
<b>Temp:</b>	-20°C ~ +55°C
<b>Storage temperature:</b>	-20°C ~ +70°C

<b>Humidity:</b>	5% - 95%
<b>Others:</b>	Color black
<b>LAN:</b>	2x RJ45 2.5Gbe LAN (Intel I225-V/I226-V chip)
<b>Wireless LAN card:</b>	Wi-Fi 5   WiFi 6E (optional)
<b>3G:</b>	No
<b>4G LTE:</b>	No
<b>Bluetooth:</b>	Bluetooth 4.2
<b>Rear Panel (ports):</b>	3x HDMI 2.0b   1x DisplayPort 1.4a   2x LAN 2.5G   2x COM (RS232/RS485) 2x USB 2.0   Phoenix connector   DC-IN
<b>Front Panel (ports):</b>	USB-C 3.0   4x USB 3.0   2x USB 2.0   MIC IN   Line-out   Power + LED
<b>Expansion:</b>	Adapter   HDMI cable   VESA mount   WiFi Antenna
<b>Power:</b>	100-240V AC - 19V DC / 3.7A
<b>Watch Dog Timer:</b>	Yes
<b>CD/DVD Drive:</b>	None
<b>TV Tuner:</b>	No
<b>Dimensions:</b>	186 x 128 x 67 mm
<b>Fanless:</b>	Yes
<b>Weight:</b>	1,63kg

**2 396,16 zł**

net price: 1 948,10 zł

# MobiPad nBOX MK12F- V2



**SPECIFICATION**

**CONNECTIVITY AND COMMUNICATION**

**RESISTANCE AND DURABILITY**

**APPLICATION**

**AVAILABLE VERSIONS**

These compact industrial units demonstrate high resistance to operation in dusty environments, ensuring completely silent operation regardless of the deployment location. The durable MobiPad nBOX MK12F-V2 utilizes a passive heat dissipation system and a metal exterior structure, allowing for efficient thermal energy transfer without the need for mechanical components. This

device is powered by a powerful Intel Core i3-1215U processor from the Alder Lake family and is designed for continuous operation 24/7, further enhanced by an automatic restart function upon power restoration. These parameters position this professional computer as the optimal foundation for complex technological systems and modern operating environments.

### Small dimensions



The compact metal casing, measuring 186 x 128 x 67 mm, allows for efficient workspace organization and facilitates transport.

### Lightweight construction



The mobile MobiPad nBOX MK12F-V2 weighs just 1.63 kg, making it easy to transport in carry-on luggage.

### Efficient processor



The use of a modern Intel Core i3-1215U processor from the Alder Lake-U family translates into high performance while simultaneously handling multiple system operations.

## Wireless Networking



The innovative MobiPad nBOX MK12F-V2 features a dedicated M.2 2230 E Key slot supporting Wi-Fi ac and ax standards, ensuring constant and fast wireless access in any location.

## Quick Start



The advanced MobiPad nBOX MK12F-V2 utilizes a storage architecture based on two M.2 2280 slots. This solution significantly accelerates the loading of complex work applications.

## Passive Cooling



The modern MobiPad nBOX MK12F-V2 model is designed with a passive fanless heat dissipation system, ensuring completely silent operation in all conditions.

[up...](#) [menu...](#)

# SPECIFICATION

## MobiPad nBOX MK12F-V2

Processor

Intel Core i3-1215U

## MobiPad nBOX MK12F-V2

Operating system	Supported: Windows 11, Windows 10, Linux
RAM DDR4	8GB
Hard Disk SSD M.2	128GB 256GB *   512GB * (optional)
Communication	WiFi 5   WiFi 6E* (optional)   Bluetooth 4.2
Connectors - front	1x USB-C 3.0   4x USB 3.0   2x USB 2.0 microphone input (MIC IN)   line output (Line out)
Connectors - rear	3x HDMI 2.0b   1x DisplayPort 1.4a   2x LAN   2x USB 2.0 2x COM ** (a choice of 2x RS232 or 2xRS485 or 1xRS232 and 1x RS485)
Dimensions	186x128x67mm
Weight	1.63kg
Graphics card	Intel UHD Graphics
Colors available	Black (Metal Housing)

\* Optional equipment available only in the appropriate product versions or upon request.

\*\* When ordering, a selection of two COM connector variants is available: 2x RS232, 2x RS485, or a mixed set (1x RS232 and 1x RS485).



Detailed device specification is available in the "Technical data".

### Efficient Processor

The innovative MobiPad nBOX MK12F-V2 is equipped with a modern and energy-

efficient Intel Core i3-1215U processor from the Alder Lake-U series. This processor features six integrated cores supporting eight threads, allowing for efficient management of multiple processes simultaneously while maintaining a low TDP of 15W. Hybrid architecture enables intelligent resource allocation and efficient communication with DDR4 RAM, directly translating into high responsiveness and system stability. This technological solution guarantees smooth operation even in demanding industrial environments, where efficiency under constant load is crucial.

[up...](#) [menu...](#)

## Passive Cooling

The reliable MobiPad nBOX MK12F-V2 utilizes fanless heat dissipation technology based on a robust metal construction. This mechanism relies on natural thermal convection through the device's outer shell, eliminating the need for any moving components. This design ensures silent operation and minimizes the likelihood of mechanical failures, while also providing an effective barrier against dust and other industrial pollutants.

## Dimensions

The compact metal design, measuring 186 x 128 x 67 mm, makes the functional MobiPad nBOX MK12F-V2 highly versatile for both modern offices and demanding production environments. A passive cooling system allows for

flexible installation in confined spaces, while full VESA mount compatibility allows for efficient mounting of the device directly behind the screen. This technical solution translates into efficient use of space on the worktop and optimized workstation design.



<b>Dimensions</b>	186mm x 128mm x 67mm
<b>Net weight</b>	1630g

[up...](#) [menu...](#)

## Connectors and Buttons

The multi-functional MobiPad nBOX MK12F-V2 features an extensive front panel that enables instant communication with external devices in demanding operating environments. The durable metal front panel, in addition to the power button and LEDs indicating system status and SSD operation, integrates a modern USB-C 3.0 interface, four high-speed USB 3.0 ports, and two additional USB 2.0 ports. The design of this unit also includes a separate microphone input and audio line output, allowing for flexible hardware adaptation to specific technological processes and the operator's current requirements.

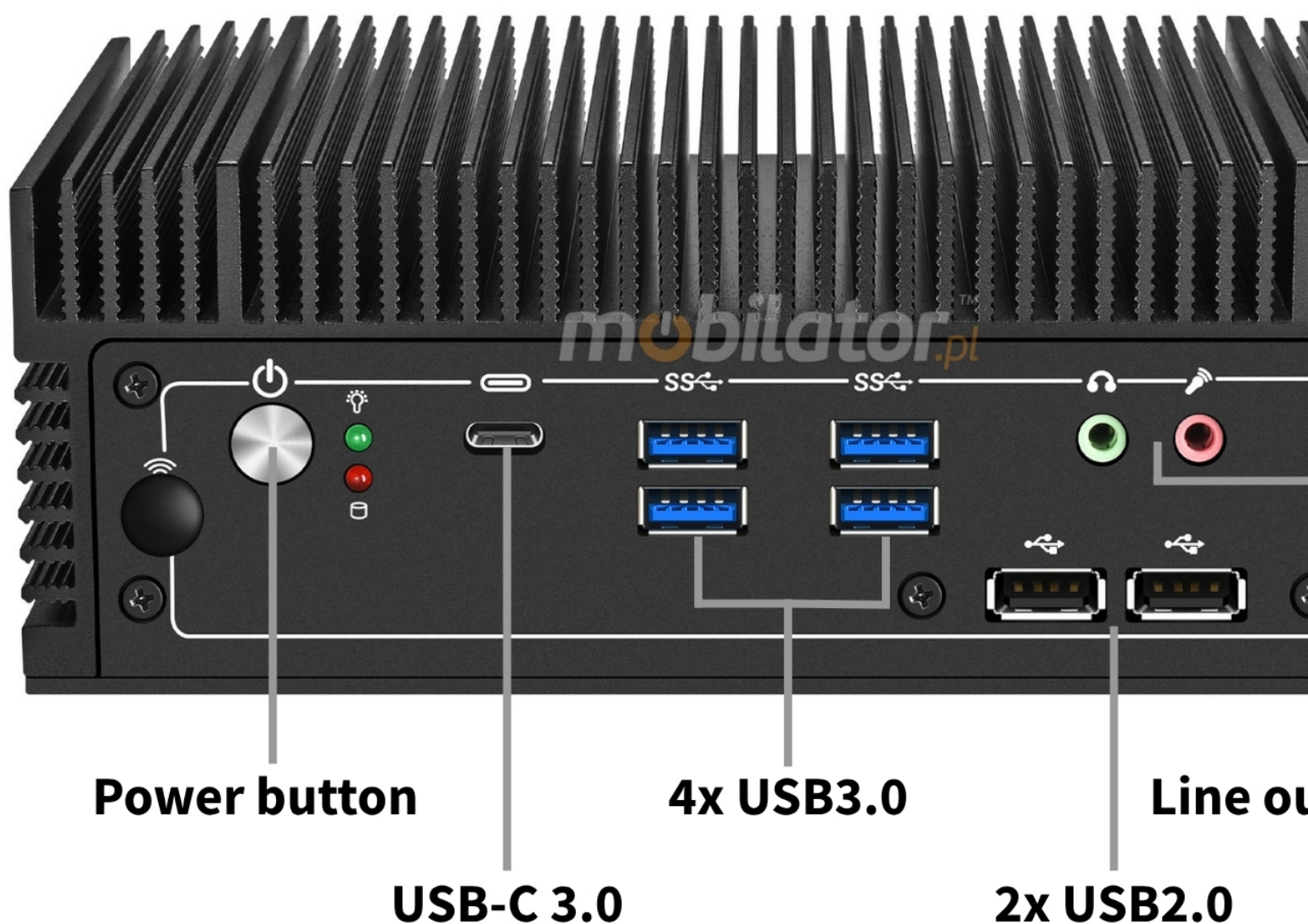

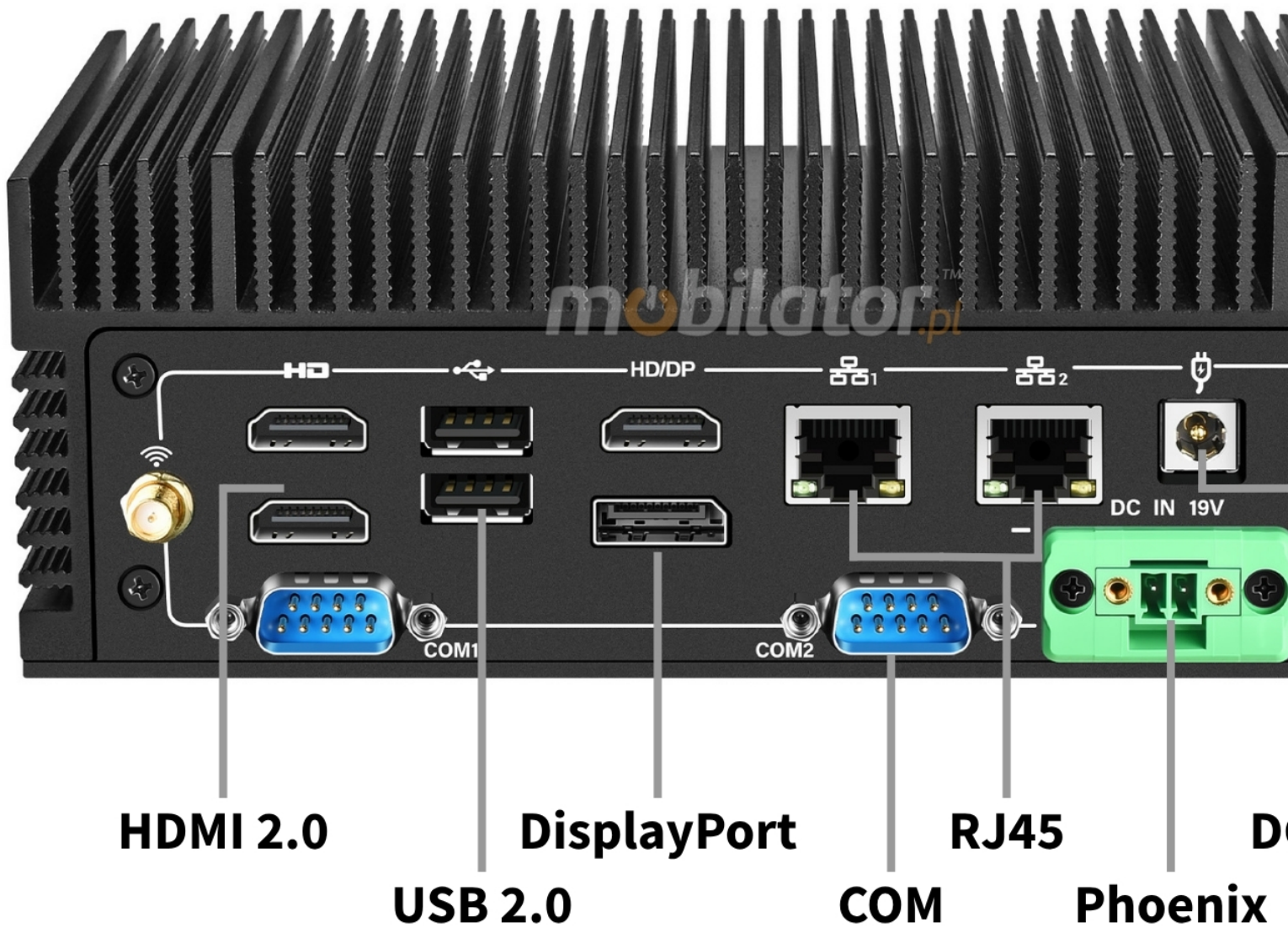

The specialized MobiPad nBOX MK12F-V2 is equipped with a comprehensive set of interfaces located on the rear panel, allowing for simultaneous operation of up to four high-resolution 4K displays at 60Hz refresh rate. Three HDMI 2.0b ports and one DisplayPort 1.4a port are available, complemented by two additional USB 2.0 ports for peripherals. Fast network communication is provided by two RJ45 ports supporting the 2.5GbE standard, based on proven Intel chips, ensuring stable data transfer in industrial infrastructure. **The unit also offers two universal serial COM ports, which, thanks to support for the RS232 and RS485 standards, can be precisely configured via jumpers to 2xRS232, 2xRS485, or**

1xRS232 and 1xRS485, according to the requirements of a specific installation.

The entire power supply system is based on the DC IN input and a Phoenix connector, which, combined with a 19V power supply, ensures continuous operation of the device in various technological conditions.

[up...](#) [menu...](#)

## CONNECTIVITY AND COMMUNICATION

### WiFi5 wireless network | (WiFi 6E) \*

The advanced MobiPad nBOX MK12F-V2 guarantees reliable wireless communication thanks to the M.2 2230 E Key slot, which supports efficient Wi-Fi standards in ac and ax technology. This configuration ensures fast and reliable data transfer in busy network infrastructures, while the integrated Bluetooth 4.2 module enables seamless synchronization with external accessories.

\* The device is available in a configuration with the WiFi 6E option.

### Wired LAN

The high-performance MobiPad nBOX MK12F-V2 is equipped with two 2.5GbE RJ45 ports, based on stable Intel I225-V or I226-V controllers. The use of a dual, high-speed network interface allows for significantly higher data throughput compared to standard Gigabit Ethernet solutions, ensuring smooth transmission in complex industrial installations. This hardware configuration allows for simultaneous operation of independent networks or the implementation of

connection redundancy mechanisms, significantly increasing security and ensuring the continuity of operational processes.

[up...](#) [menu...](#)

## RESISTANCE AND DURABILITY

### Mechanical Damage

The robust MobiPad nBOX MK12F-V2 is characterized by significant resistance to vibration and accidental mechanical damage thanks to the use of passive fanless cooling technology paired with a fast M.2 NVMe SSD.



The complete elimination of moving components within the metal housing

translates into a highly shock-resistant design, enabling safe and uninterrupted operation in areas exposed to intense vibrations. This hardware architecture effectively protects key components, including the energy-efficient Intel Core i3-1215U processor, and collected data from the negative effects of operating in a harsh physical environment.

## Extreme Temperatures

The rugged MobiPad nBOX MK12F-V2 is fully adapted to continuous operation in demanding thermal environments, maintaining impeccable operational stability within a wide range of -20°C to 55°C. The use of a durable metal housing and a passive heat dissipation system allows for effective thermal energy dissipation even during intense processor load. These technical features ensure this industrial-grade device ensures full operational efficiency in the most demanding locations characterized by variable thermal conditions.

<b>Operating Temperature</b>	-20°C to 55°C
<b>Temperature Storage</b>	-20°C to 70°C
<b>Humidity</b>	5% to 95%

[up...](#) [menu...](#)

## APPLICATIONS

## Retail and Services

The versatile MobiPad nBOX MK12F-V2 is an effective tool for the retail and service sectors, where its compact design streamlines invoicing and inventory management processes. The fanless cooling system ensures completely silent operation in customer service areas, eliminating unnecessary noise levels in the workplace. The VESA 70x70 mm or 100x100 mm mount allows for quick installation on the back of a monitor or under a desk, allowing for optimal use of limited space in stores and logistics locations.



## Warehouse and Logistics

The powerful MobiPad nBOX MK12F-V2, thanks to the powerful computing resources of an Intel Core i3-1215U processor from the Alder Lake-U family, enables simultaneous operation of complex warehouse management systems. Its robust metal casing ensures long-term, trouble-free operation in dusty warehouses, maintaining full operational stability across a wide temperature range. A passive cooling system eliminates the risk of mechanical failures, which, combined with the energy-efficient architecture of the Intel chip with a 15W TDP, makes this unit an optimal solution for modern logistics centers.



## Transportation and Automotive

The professional MobiPad nBOX MK12F-V2 demonstrates significant utility in the transportation and automotive industries, supported by an integrated DC IN power input and the included 19V 3.7A power supply. This solution is suitable for use in public transportation vehicles, trains, and aircraft, enabling efficient operation of passenger information systems and real-time diagnostics of technical parameters. Its compact dimensions allow for flexible installation in space-constrained environments, while the passive fanless cooling system

ensures stable operation and high resistance to constant vibration and shock.



[up...](#) [menu...](#)



More photos in full resolution available in the "Gallery".

## AVAILABLE VERSIONS

The flexible MobiPad nBOX MK12F-V2 is available in a variety of performance variants, allowing for optimal adjustment of device parameters to specific design objectives. Selecting a specific configuration from the hardware list allows you to view detailed technical specifications for the selected model. For situations

requiring a non-standard approach, personalized technical specifications can be prepared to precisely meet the unique operational needs of a given industrial implementation.

	v.1	v.2	v.3	v.3.1	v.4
Windows 11 PRO	—	—	—		—
WiFi 6E	—	—			—
8GB RAM	—				
128GB SSD M.2 -NVMe	—		—	—	—
256GB SSD M.2 -NVMe	—	—			—
512GB SSD M.2 -NVMe	—	—	—	—	