



MoTouch 185 v.2 - Reinforced industrial touch monitor - IP65 standard for the front

<b>Category:</b>	Industrial touch screens
<b>Manufacturer:</b>	Mobikator
<b>Screen size:</b>	18,5"
<b>Resolution:</b>	1920x1080
<b>Aspect ratio:</b>	16:9
<b>Brightness:</b>	300 cd/m2
<b>Touchscreen:</b>	Resistive
<b>IP Norm:</b>	IP 65 on front
<b>IP Level (back panel):</b>	-----
<b>IP Level (front panel):</b>	IP 65
<b>Temp:</b>	-10°C ~ 60°C
<b>Storage Temp:</b>	-20°C ~ 70°C
<b>Humidity:</b>	to 95%
<b>Anti-shock:</b>	-----
<b>Anti-vibration:</b>	-----
<b>Others:</b>	-----
<b>Ports - rear panel:</b>	1x VGA, 1x HDMI, 1x DVI, 1x DC-IN, 1x RJ-45 (touch connector), 1x Audio I/O

<b>Built-in speakers:</b>	No
<b>Expansion:</b>	-----
<b>Power:</b>	12V~36V DC
<b>Power Consumption:</b>	18 W
<b>Mounting VESA:</b>	Panel, Wall, Rack, Stand and Arm
<b>Folding Bracket (for office type working):</b>	No (optional)
<b>Backlight MTBF:</b>	TFT LCD
<b>Response time touch-panel (ms):</b>	10 ms
<b>Contrast Ratio:</b>	1000:1
<b>Viewing Angle:</b>	85/85/80/80 (L/R/U/D)
<b>Color Resolution:</b>	16.7M
<b>Touch Life(contacts):</b>	Infinity
<b>Surface hardness (display):</b>	-
<b>Housing material:</b>	rugged 3mm thickness aluminum
<b>Dimensions:</b>	486.5mm x 307.4mm x 67mm
<b>Weight:</b>	6 kg

**2 532,26 zł**

net price: 2 058,75 zł

# MoTouch 185



## Menu

❖ Description

❖ Connector

❖ Screen

❖ Application

❖ Specifications

## Industrial Touch Monitors

Small dimensions Industrial Panel Monitor are used in environments dominated by dust, dirt and moisture. They are ideal for applications requiring quiet and continuous operation. Industrial touch screen monitor, through its function of touch, replaces: mouse, keyboard, or other pointing device.

[go top...](#) [menu...](#)



Mobilator	MoTouch 185	
		Resolution: 1920x1080 / 16:9
		LCD size: 18,5"
		Backlight: TFT LCD
		Connectors:VGA/DVI/HDMI/Audio I/O
		Screen Protection: -

	<b>Mounting:</b> 75mm x 75mm / 100mm x 100mm
	<b>Built-in speakers:</b> -
	Detailed specification of the configuration available in the " <b>Technical data</b> "

### Dimensions:

Housing dimension are **486 x 307.4 x 67 mm**. Housing is made of high quality aluminum what ensures a very high resistance to mechanical damages. This model with weight of only **6 kg** is ready at any time for operation even in extreme conditions such as heat, cold, vibration.

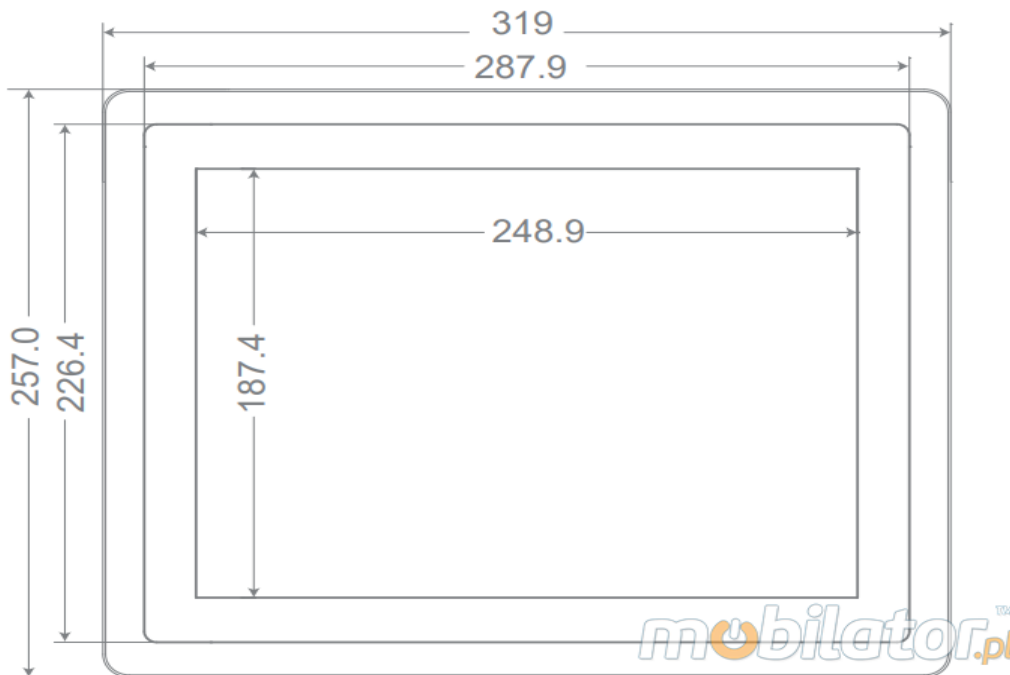

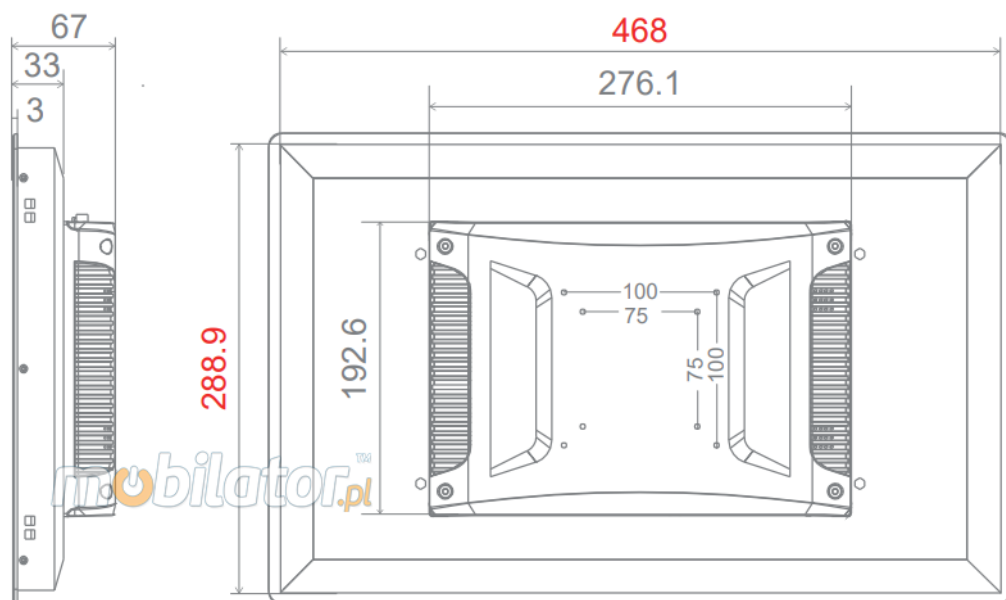

[go top...](#) [menu...](#)

Connector

For proper operation of the touch controller is needed connect the monitor to the computer using the USB cable.

**Connector:**

Touch monitor MoTouch 185 is equipped with the essential connectors such as:

1. RJ-45 (touch connector)	3. DVI	5. Audio I/O
2. HDMI	4. VGA	6. DC-IN





# Screen

MoTouch 185 With 1920x1080 resolution and high brightness of 300 cd/m2, screen of capacitive type with high sensitivity to touch, offers the user a clear picture and ease of use.

The LCD monitor has backlight TFT LCD. This technology allows for the construction and easy control of high-resolution displays, as well as obtaining much higher image quality.



## Resistive screen

The touch-sensitive surface is made of two plastic plates. The surface plate is made of thin and scratch-resistant plastic. It is also covered with a thin layer of conductive materials (tin oxide and indium oxide) placed on the bottom of the "glass". There is a second plastic plate under the upper glass (i.e. below the conductive material). The two plates have no contact with each other until the user of the device presses the screen with a finger or stylus. Contact then occurs between slightly separated

asurement of vertical and horizontal

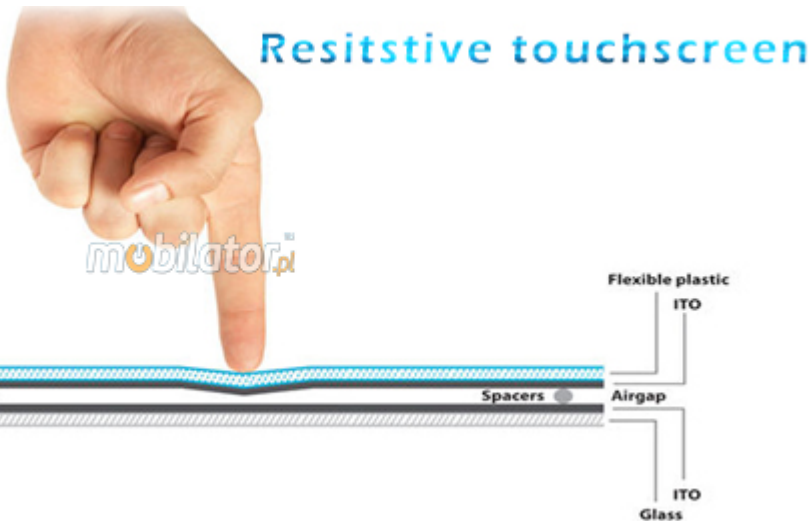

The resistive screen provides good

visibility, but it decreases quite significantly in the sun. This type of screen, unlike a capacitive screen, allows the use of

