



Reinforced Capacitive Industrial Panel PC - Android MobiBOX IP65 A150

Category:	Industrial Panel PC Computers
Manufacturer:	Mobilator
Supported OS:	Android
Installed OS:	Android 6.0
Screen size:	15"
Resolution:	1024 x 768
Aspect ratio:	4:3
Brightness:	400 cd/m2
Touchscreen:	Capacitive
CPU Support:	A64 Quad-Core ARM Cortex-A53
Installed CPU:	ARM Cortex-A53 (4x1.5GHz)
Graphic Card:	Mali400MP2 GPU
Storage (HDD) Support:	8GB eMMC
Installed Storage (HDD):	8GB eMMC
Memory Support:	up to 2GB

Installed Memory:	2GB
IP Norm:	IP65 (przedni panel)
IP Level (front panel):	IP65
IP Level (back panel):	-----
Temp:	-10°C ~ 60°C
Storage Temp:	-30°C ~ 60°C
Humidity:	10%~ 90%
Anti-shock:	-----
Anti-vibration:	-----
Barcode reader:	-----
RFID scanner (reader):	-----
Others:	Housing color: Black or Silver
LAN:	Yes
Wireless LAN card:	Yes
3G:	No
Bluetooth:	Yes, 4.0
GPS:	No
Ports - rear panel:	1x HDMI1x RS-2322x USB 2.01x VGA1x LAN1x DC-in1x SIM1x SD
Ports - front panel:	-----
Ports - left panel:	-----
Ports - right panel:	-----
Expansion:	-----
Power:	12V DC-in
Power Consumption:	-----
Watch Dog Timer:	-----
Mounting VESA:	Yes
Folding Bracket (for office type working):	Yes
Chipset:	ARM

CD/DVD Drive:	-----
Audio:	-----
TV Tuner:	-----
Backlight MTBF:	LED
Contrast Ratio:	1000:1
Dual display:	Yes
Viewing Angle:	-----
Touch Life(contacts):	-----
Surface hardness (display):	-----
Color Resolution:	16.7 M
Response time touch-panel (ms):	5
Housing material:	Aluminum
Dimensions:	350.48mm x 296.42mm x 59,7mm
Fanless:	Yes
Weight:	5kg

2 338,54 zł

net price: 1 901,25 zł

MobiBOX IP65 A150
15"



SPECIFICATION AND PARAMETERS

DISPLAY AND TOUCH

RESISTANCE AND PROTECTION

COMMUNICATION AND CONNECTORS

APPLICATION

Industrial PC panels are integrated devices consisting of a PC computer and a touch monitor. Due to their design, they can work even under severe conditions prevailing in industrial environments, such as high humidity, high dustiness, contact with water or very low or high temperatures. These panels are characterized by high efficiency and stability of operation in all conditions.



Waterproof

The IPX5 water-resistance standard on the front panel guarantees protection of the device for contact with water.

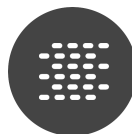

Dustproof

The dustproof IP6X standard on the front panel protects the panel against dust and access to hazardous parts.



Efficient

The quad-core ARM Cortex-A53 processor supported by 2GB of RAM improves the device's performance.



Bright Screen

The display with 400cd/ m² brightness makes the picture much more vivid and better readable when used outside in the sun.



Wireless network

The panel can be connected to nearby wireless networks by equipping it with an optional Wi-Fi module.



Capacitive screen

The capacitive screen allows precise handling and gentle on-screen movement.

Specifications and parameters

Performance

Processor	ARM Cortex-A53 (4x 1.5GHz)
Graphics card	Mali400MP2 GPU
Operating system	Android 6.0
RAM	2GB
Drive	8GB eMMC
Display	
Screen	15" (1024x768)
Touch screen	Capacitive
Brightness	400cd/m ²
Contrast	1000:1
Response time	5ms
Hardness	—
Interfaces	
Communication	Wi-Fi
Connectors	HDMI / VGA / RJ45 / 2x USB 2.0 / RS232 / Audio / DC 12V
Memory card	SD
SIM card	1* SIM
Other	
Protection	IP65 (front panel)
Dimensions	350.48mm x 296.42mm x 59,7mm
Weight	5kg



Detailed device specification is available in the "Technical data".

The dust-proof industrial PC panel uses an efficient and energy-saving ARM Cortex 53 processor. In its interior there are four cooperating cores enabling more efficient processing of many tasks at the same time. Shared cache memory in which a multi-level hierarchy is used is dynamically allocated to each processor core depending on the load. This reduces the average access time to the main memory. Improved graphics card technology allows you to enjoy movies at full resolution and HD quality.

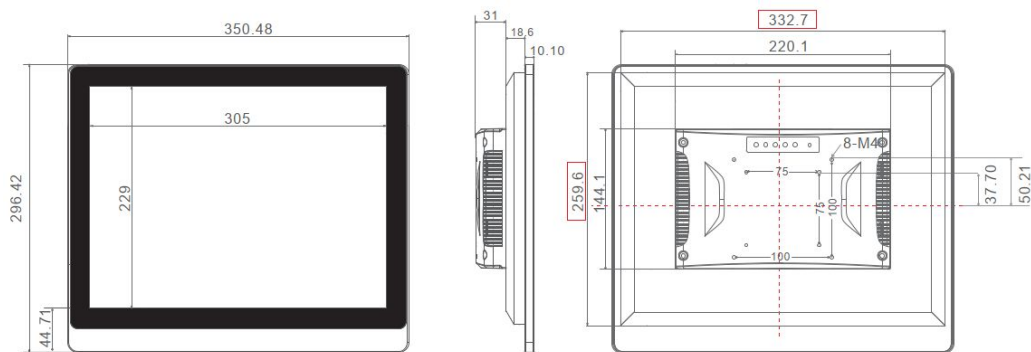

More photos in full resolution available in the "Gallery".

Display and touch

Amplified, waterproof industrial computer MobiBOX IP65 A150 has a water-resistant and scratch-proof 15" LCD screen 1024x768 resolution offers good image quality, and high brightness in the 400 cd/m² range gives better color saturation and contrast and allows significantly improved visibility even in the case of incident.

CAPACITIVE SCREEN

In the capacitive screen, the reaction of the device is not to directly press the screen, but to change the electrostatic field at the point where the device is touched.

This allows for much more precise handling and gentle brushes on the screen.

In addition, we can use multitouch technology, the ability to control our screen with a few fingers at once.



Resistance and protection

PROTECTION STANDARD **IP65**

IP norm (International Protection Rating) determines the degree of protection provided by the housing of an electrical device against such factors as: access to dangerous parts inside the housing, penetration of foreign solids and splashing or immersion. The first characteristic number means that the housing protects people against access to dangerous parts located inside the device, and at the same time provides protection against penetration of foreign solids. The second characteristic digit means that the housing provides protection against the effects of water penetration.

IP6X (front panel)	Protection against access to dangerous parts with wire. Dustproof protection.
IPX5 (front panel)	Water projected by a nozzle (6.3 mm) against enclosure from any direction shall have no harmful effects.



EXTREME TEMPERATURES

PanelPC MobiBOX IP65 A150 is adapted for continuous operation in both very low and high temperatures in the range from -10°C to 60°C . If the device is switched off, it can already handle temperatures between -30°C and 60°C . In addition, the durable PanelPC is perfect for rooms with increased humidity, ensuring proper functioning even in the case of 90% relative humidity.

Work temp.	-10°C to 60°C
Storage temp.	-30°C to 60°C
Humidity	10% - 90%

Communication and connectors

WIRELESS WI-FI NETWORK

The dual-band Wi-Fi module provides quick access to the network wherever you can connect to secured or open Wi-Fi networks. This is a convenient solution for people who have a router at home or place of residence and a wireless network that can be used at no extra charge. The shockproof industrial panel MobiBOX IP65 A150 has been equipped with standards - 802.11n, which allows transfer of files at a dizzying speed of up to 150 Mb/s.

Standards	802.11a/b/g/n
Frequencies	2.4GHz 5GHz

CONNECTORS AND INTERFACES

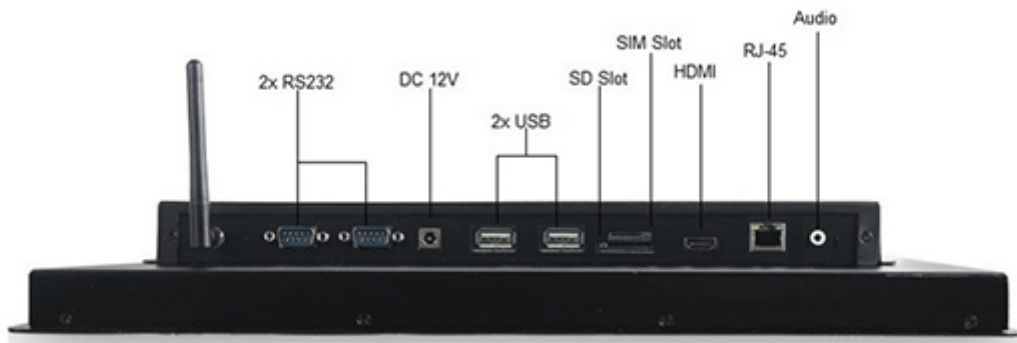

Application

TRADE AND SERVICES

Waterproof and dustproof PC Panel is widely used primarily in the commercial industry, for example for controlling the sales system, displaying product information on monitors or advertising on large screens. With the VESA holder in the housing there are many possibilities for its assembly, eg in stores (at the cash register) in factory halls, in a car delivering products, etc. It will certainly be used in all types of retail chains.

WAREHOUSE AND MANAGEMENT

The industrial panel computer thanks to the RS232 interface can be used to connect many devices in the warehouse and facilitate their control. And its rugged housing is ideally suited to the harsh conditions prevailing in such rooms. No dust or dirt will prevent him from working, he will work without complaints even in a large dusty and dirty environment.

TRANSPORT AND **MOTORIZATION**

Panel computers can be used in transport by adapting it to work on 12V power supply. Then Panel PC can be used in passenger cars, buses, trams, taxis, trains and even in airplanes. Thanks to the integrated monitor, these panels perform very well in vehicles where mobility and the small size of the device are important.