



IP65



Touch Panel PC GESHEM GS1251HT v.0

Category:	Industrial Panel PC Computers
Manufacturer:	Geshem
Supported OS:	Windows 7 / 8 / Linux
Installed OS:	-----
Screen size:	12.1"
Resolution:	1024 x 768
Aspect ratio:	4:3
Brightness:	300 cd/m2
Touchscreen:	5-wire Resistive
CPU Support:	Intel Celeron J1900 (4x 2.00GHz)
Installed CPU:	Intel Celeron J1900 (4x 2.00GHz)
Graphic Card:	Intel HD Graphics
Storage (HDD) Support:	32GB/64GB/128GB/256GB SSD
Installed Storage (HDD):	64GB SSD
Memory Support:	up to 4GB DDR3

Installed Memory:	2GB
IP Norm:	IP65 (przedni panel)
IP Level (front panel):	IP65
IP Level (back panel):	-----
Temp:	-20°C ~ 60°C
Storage Temp:	-30°C ~ 70°C
Humidity:	5%~ 95%
Anti-shock:	-----
Anti-vibration:	-----
Barcode reader:	-----
RFID scanner (reader):	-----
Others:	Housing color: Silver, Black, White
LAN:	2x Intel i211 Gigabit Ethernet RJ45
Wireless LAN card:	No
3G:	No
Bluetooth:	No
GPS:	No
Ports - rear panel:	1x VGA 2x RJ45 Gigabit Ethernet 4x USB (2x USB2.0, 2x USB3.0) 4x RS232 1x Audio 1x Mic DC 12V
Ports - front panel:	-----
Ports - left panel:	-----
Ports - right panel:	-----
Expansion:	-----
Power:	12V DC-in
Power Consumption:	15W
Watch Dog Timer:	-----
Mounting VESA:	Yes
Folding Bracket (for office type working):	-----
Chipset:	Intel

CD/DVD Drive:	-----
Audio:	RTL ALC662 6-Channel HD Audio
TV Tuner:	-----
Backlight MTBF:	LED
Contrast Ratio:	400:1
Dual display:	Nie
Viewing Angle:	-----
Touch Life(contacts):	-----
Surface hardness (display):	-----
Color Resolution:	-----
Response time touch-panel (ms):	-----
Housing material:	Aluminum
Dimensions:	288mm x 226mm x 60,6mm
Fanless:	Yes
Weight:	3.5kg

Product from the Archive - production finished

GESHEM 12



SPECIFICATION AND PARAMETERS

DISPLAY AND TOUCH

RESISTANCE AND PROTECTION

COMMUNICATION AND CONNECTORS

APPLICATION

AVAILABLE VERSIONS AND ACCESSORIES

Industrial PC panels are integrated devices consisting of a PC computer and a touch monitor. Due to their design, they can work even under severe conditions prevailing in industrial environments, such as high humidity, high dustiness, contact with water or very low or high temperatures. These panels are characterized by high efficiency and stability of operation in all conditions.



Waterproof

The IPX5 water-resistance standard on the front panel guarantees protection of the device for contact with water.

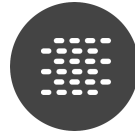

Dustproof

The dustproof IP6X standard on the front panel protects the panel against dust and access to hazardous parts.



Efficient

The quad-core Intel Celeron processor supported by 2GB of RAM improves the device's performance.



Bright Screen

The display with 300cd/ m² brightness makes the picture much more vivid and better readable when used outside in the sun.



Wireless network

The panel can be connected to nearby wireless networks by equipping it with an optional Wi-Fi module.



Resistive screen

The resistive screen allows you to freely use the touch screen of the PC panel in gloves or with a stylus.

Specifications and parameters

Performance	
Processor	Intel Celeron J1900 (4x 2.00GHz)
Graphics card	Intel HD Graphics
Operating system	Windows 7 / 8 / Linux
RAM	2GB DDR3
Drive	64GB SSD
Display	
Screen	12.1" (1024x768)
Touch screen	Resistive 5-wire
Brightness	300cd/m ²
Contrast	400:1
Response time	—
Hardness	—
Interfaces	
Communication	Wi-Fi & Bluetooth *
Connectors	VGA / 2x RJ45 / 4x USB / 4x RS232 1x Audio / 1x Mic / DC 12V
Memory card	—
SIM card	—
Other	

Protection	IP65 (front panel)
Dimensions	288mm x 226mm x 60,6mm
Weight	3.5kg

* Optional equipment, available only in specific versions of the device.

 Detailed device specification is available in the "Technical data".

The dust-proof industrial PC panel uses an efficient and energy-saving Intel Celeron J1900 processor. In its interior there are four cooperating cores enabling more efficient processing of many tasks at the same time. Shared cache memory in which a multi-level hierarchy is used is dynamically allocated to each processor core depending on the load. This reduces the average access time to the main memory. Improved graphics card technology allows you to enjoy movies at full resolution and HD quality.

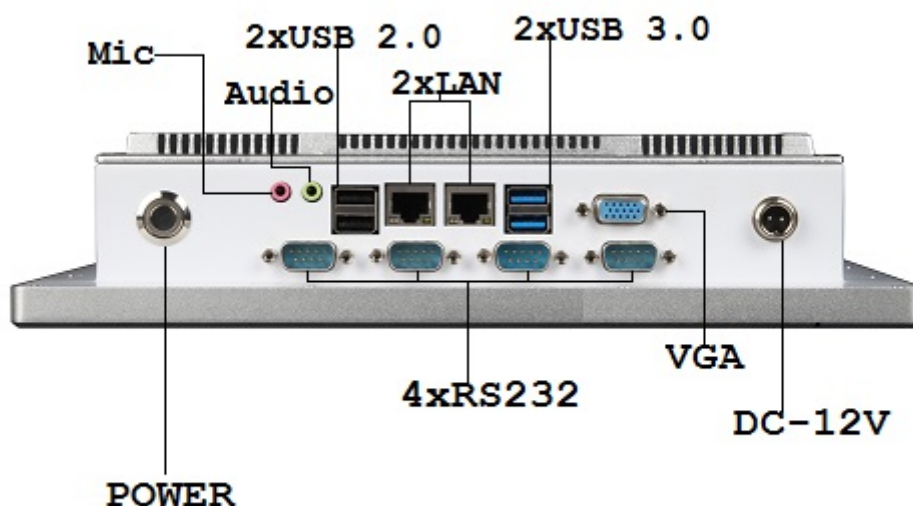



More photos in full resolution available in the "Gallery"

Display and touch

Amplified, waterproof industrial computer GESHEM GS1251HT has a water-resistant and scratch-proof 12.1" TFT LED screen 1024x768 resolution offers good image quality, and high brightness in the 300 cd/m² range gives better color saturation and contrast and allows significantly improved visibility even in the case of incident. The display of the resistive type provides the user with a clear image and ease of use by touch.

RESISTIVE SCREEN

In the resistive screen, the sensitive surface is made of two plastic plates. The plate on the surface is made of thin and scratch-resistant plastic. It is also covered with a thin layer of conductive materials placed on the bottom of the screen. Under the top glass (i.e. below the conductive material) is a second plastic plate. Both tiles have no contact with each other until the user of the device has pressed the screen with a finger or stylus. Then there is contact between slightly separated screens. As a result of their contact, a short-circuit is created, which by measuring the vertical and horizontal resistance is converted into data indicating the processor's contact point.

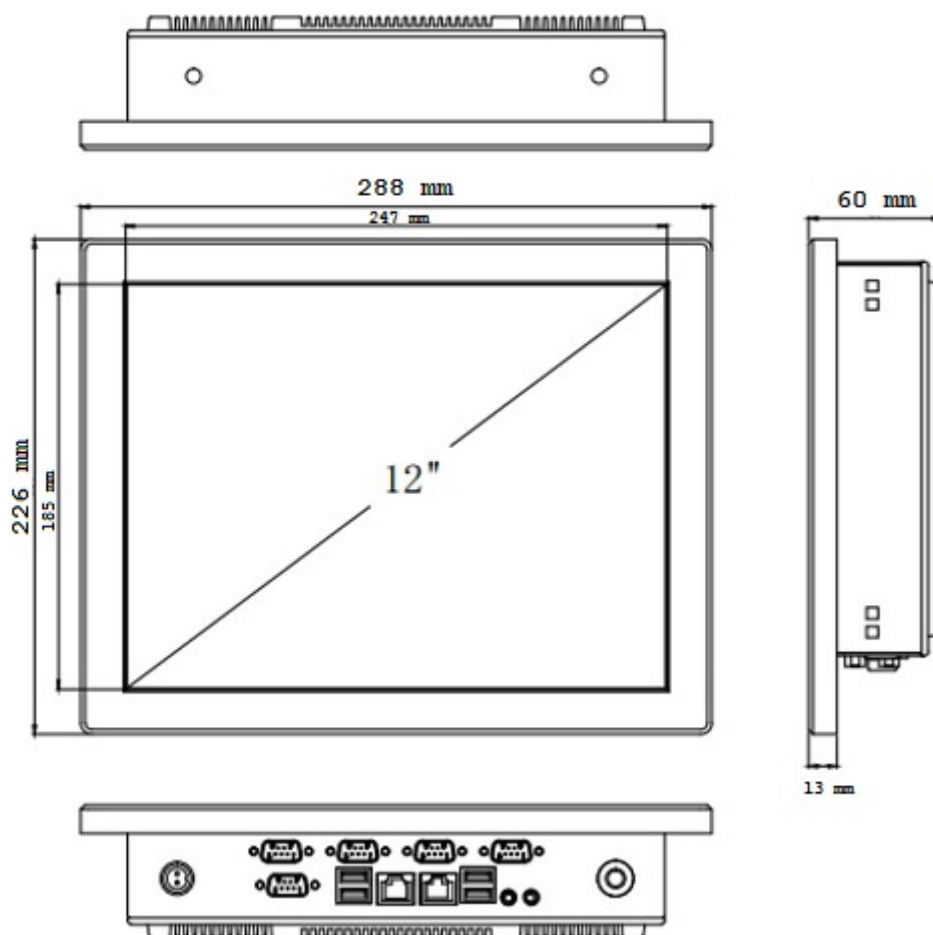

Resistance and protection

PROTECTION STANDARD **IP65**

IP norm (International Protection Rating) determines the degree of protection provided by the housing of an electrical device against such factors as: access to dangerous parts inside the housing, penetration of foreign solids and splashing or immersion. The first characteristic number means that the housing protects people against access to dangerous parts located inside the

device, and at the same time provides protection against penetration of foreign solids. The second characteristic digit means that the housing provides protection against the effects of water penetration.

IP6X (front panel)	Protection against access to dangerous parts with wire. Dustproof protection.
IPX5 (front panel)	Water projected by a nozzle (6.3 mm) against enclosure from any direction shall have no harmful effects.



EXTREME TEMPERATURES

PanelPC GESHEM GS1251HT is adapted for continuous operation in both very low and high temperatures in the range from -20 ° C to 60 ° C. If the device is switched off, it can already handle temperatures between -30 ° C and 70 ° C. In addition, the durable PanelPC is perfect for rooms with increased humidity, ensuring proper functioning even in the case of 95% relative humidity.

Work temp.	-20°C to 60°C
Storage temp.	-30°C to 70°C
Humidity	95%

Communication

WIRELESS WI-FI NETWORK (OPTION)

The dual-band Wi-Fi module provides quick access to the network wherever you can connect to secured or open Wi-Fi networks. This is a convenient solution for people who have a router at home or place of residence and a wireless network that can be used at no extra charge. The shockproof industrial panel GESHEM 1251HT can be equipped with standard - 802.11ac, which allows transfer of files at a dizzying speed of up to 433 Mb/s.

Standards	802.11a/b/g/n/ac
Frequencies	2.4GHz 5GHz

WIRED LAN NETWORK

Panel PC have built-in two ethernet cards - Intel i211. They can work in gigabit network.

Standard	IEEE 802.3ab - 1000Base-T
Speed	1Gb/s

Application

TRADE AND SERVICES

Waterproof and dustproof PC Panel is widely used primarily in the commercial industry, for example for controlling the sales system, displaying product information on monitors or advertising on large screens. With the VESA holder in the housing there are many possibilities for its assembly, eg in stores (at the cash register) in factory halls, in a car delivering products, etc. It will certainly be used in all types of retail chains.

WAREHOUSE AND MANAGEMENT

The industrial panel computer thanks to the RS232 interface can be used to connect many devices in the warehouse and facilitate their control. And its rugged housing is ideally suited to the harsh conditions prevailing in such rooms. No dust or dirt will prevent him from working, he will work without complaints even in a large dusty and dirty environment.

TRANSPORT AND **MOTORIZATION**

Panel computers can be used in transport by adapting it to work on 12V power supply. Then Panel PC can be used in passenger cars, buses, trams, taxis, trains and even in airplanes. Thanks to the integrated monitor, these panels perform very well in vehicles where mobility and the small size of the device are important.

Available versions and accessories

Industrial industrial computer GESHEM GS1251HT is offered in several versions adapted to different needs. By clicking on the number of the hardware configuration you will be redirected to the product with the parameters given in the table below. In addition, it is possible to create a configuration that is currently unavailable on the customer's request.

	v.0	v.1	v.2
2GB RAM		—	—
4GB RAM	—		
64GB SSD			
WiFi Intel AC-3165	—	—	
Bluetooth	—	—	